

A new structure for bidirectional Power flow

Seyed Borhan azimi

AmirKabir Univ. of Technology

Hassan Ghafoori Fard

AmirKabir Univ. of Technology

Abstract: In this paper, methods of energy recovery for electric motors in braking mode are presented. Also for motors with low and medium regenerative power, a low cost and simple structure is proposed. In this method, for converting the high voltage of DC bus to AC voltage equal to transmission line voltage, center-tap capacitors are used for transformer independency. Also by considering regenerative power produced by two methods, it is shown that both circuits based on PWM and natural commutation can be used for regeneration. Finally, simulation results in addition to comparison between harmonic contents of the proposed and conventional methods for a 3-phase, 4KW SR motor is presented.

Keywords: Regenerative Brake , Energy saving, bidirectional power flow

1. Introduction

Regenerative energy recovery from motors in the brake mode is one of Considerable subjects in recent years. The dc link for the inverter is often fed with a diode bridge, which allows power flow only in the 'motoring' direction. During braking, energy is fed back through the inverter to the dc link. This braking energy, unless disposed of, can result in a dangerous build-up of voltage across the dc bus. A common solution, shown in Fig.1, is to dissipate the energy in a 'dynamic brake' resistor that is placed across the dc link when the dc bus voltage exceeds its normal levels [1,2]. For applications requiring frequent braking, this entails considerable losses and heat generation.

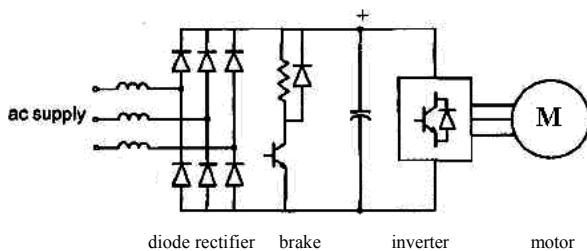

Fig 1: Dynamic brake resistor method

Several alternatives are available to feed the braking energy back into the ac mains. The traditional approach uses a reverse-connected SCR bridge to invert the regenerative power back into the mains [1-3]. Natural commutation can be sustained as long as the peak mains voltage exceeds the dc bus voltage. This is difficult, at best, to achieve in a drive with a diode front-end, since the dc bus is charged to the peak line-line voltage during regular operation and rises above this level during regeneration. A widely used solution, shown in Fig.2, is to use a phase-backed SCR rectifier and operate the converter at reduced dc link voltage during normal rectification. This ensures that the dc bus voltage is low enough to maintain safe commutation of the inverting SCR bridge as the drive enters the regeneration mode. In another common scheme, shown in Fig. 3, the inverting bridge is connected through an autotransformer to allow adequate commutation margins [4,5].

To avoid the deficiencies imposed by line commutation, several approaches have been proposed which augment the inverting bridge with self-turn-off devices to ensure reliable commutations [4,5].

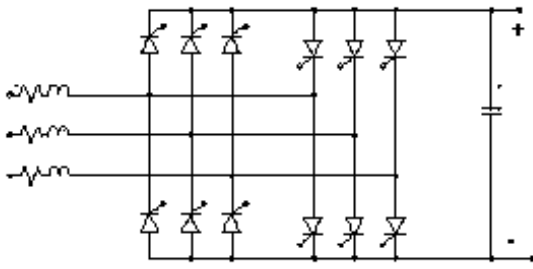

Fig 2: Dual SCR bridge front-end

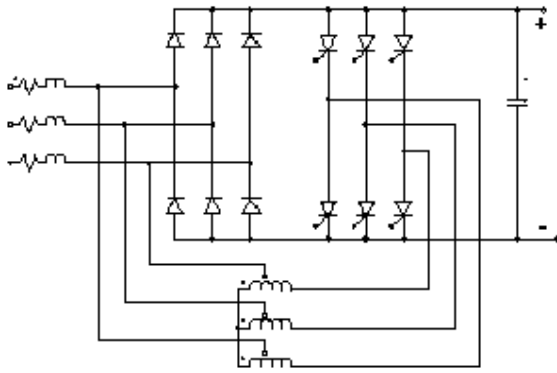

Fig 3: Autotransformer-connected SCR bridge

Fig. 4 shows a scheme in which commutation of the bridge thyristors is performed by two turn-off switches connected to the positive and negative rails [4,5]. Fig. 5 shows a different approach in which a reversing bridge is connected between a SCR front-end and the dc bus [5,6,7]. Regeneration is achieved by connecting the dc bus in reverse to the phase-controlled rectifier.

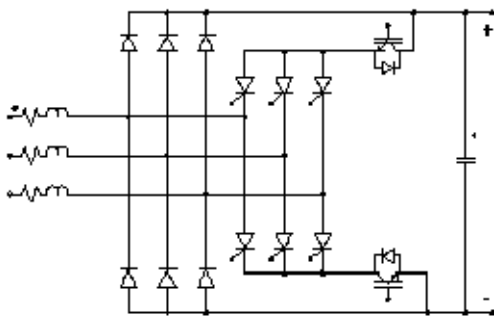

Fig 4: SCR Bridge with turn-off switches

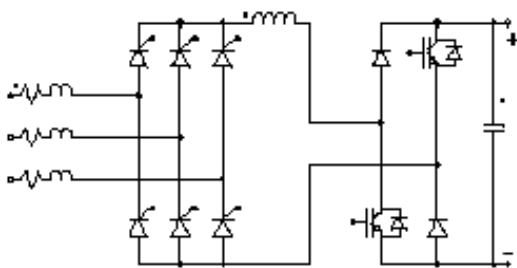

Fig 5: SCR rectifier with reversing bridge

Another common approach, shown in Fig. 6 is to use a PWM rectifier instead of a diode bridge in the front-end [2]. This circuit, in addition to bidirectional power flow, provides dc bus voltage control and harmonic-free unity power factor operation. This approach, while having many advantages, is expensive since the machine-side inverter is essentially replicated.

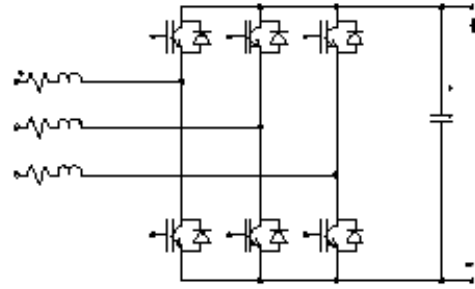

Fig 6: PWM rectifier front-end

2. Proposed Method

In motors with low and medium power, because of low regenerative power, use of 3-phase regenerative Brake is not economical, so in this paper, a low cost and simple structure for single phase use is proposed. In this structure that is based on half bridge inverter [10], only two IGBT switches are needed and so need for transformer is resolved. Diagram of proposed structure is shown in Fig 7:

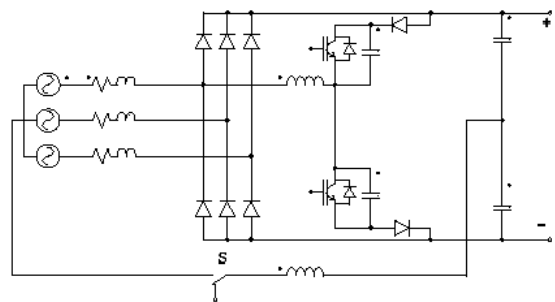

Fig 7: Proposed inverter with capacitor voltage divider

The structure of Fig 7 can return energy to line by two methods. In the first method – called A- during regeneration, switch S_n is turned on and so IGBTs are sequentially gated to transfer power from the dc bus capacitors to the supply phases. In this case, IGBT's current will decrease as long as the peak line-neutral voltage exceeds the voltages across each of the capacitors and

natural commutation can be achieved. To limit the current on the IGBT, an inductor whose impedance is manifold of AC line impedance is used, and so turn on and turn off angles of IGBTs are second factor in limitation of IGBT current. By controlling the value of regeneration current, average regenerative current and proportionally, the dc bus voltage can be controlled. If the bus voltage is less than V_{p-p} , the current will flow to bus from the rectifier diodes and voltage will be increased, thus V_{p-p} is minimum of the dc bus voltage that can be controlled. In the second method – method B- we use PWM modulation to generate sinusoidal voltage synchronous with the phase. The use of center-tap capacitor in this method also will eliminate the use of transformer. The need for accurate synchronization is the disadvantage of this method and will increase complexity of the system. So, switching loss in this method is greater than method A, but less harmonic generation in voltage and current is the advantage of this method with respect to method A.

3. Analyse of Operation

Since the structure of Fig. 7 uses the IGBT switches, current control by hysteresis method can be achieved. To control the dc bus voltage, it is necessary to calculate the turn on and turn off angles. To do this, we equalize the average of regenerative current of motor to average of current returned to line. By using KVL in the upper loop of circuit in the fig.7 we have:

$$L \frac{di_a}{dt} = V_m \sin(\omega t) - \frac{V_{dc}}{2} \quad (1)$$

If we call the turn on angle with respect to zero crossing angle of phase by α we have:

$$i_a = \frac{V_m}{L\omega} [\cos(\alpha) - \cos(\omega t)] - \frac{V_{dc}}{2L} (\omega t - \alpha) \quad (2)$$

And if turn off angle, called β :

$$I_{Brake} = \int_{\alpha}^{\beta} i_a d(\omega t) \quad (3)$$

That I_{Brake} is average of regeneration current that is achieved by simulation. So for design, by using the average of regeneration current, we can calculate the α and β angles and maximum of i_a and by using i_{a_max} and V_{bus} we can chose the inductance L.

4. Computer Simulation

To check the operation of proposed structure, computer simulation of A and B methods associated with simulation of a single-phase PWM with transformer –method C (Fig.8)- using Spice are presented. For simulation, model of a switched reluctance motor in the generation mode is used. Because of the SRM's significant incremental phase inductance and the fact that its excitation is controlled on a cycle by cycle basis, the SRG behaves more like a current source than a voltage source [9]. So, for acceleration to simulation, we can use equivalent current source- that has been obtained later by simulation- in the new simulation.

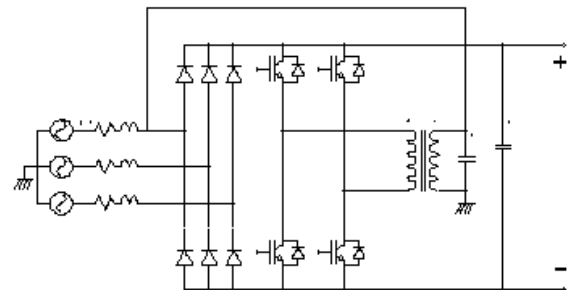

Fig 8: Single phase PWM inverter with Transformer

Other parameters of simulation are presented below:

$V_{Line(peak)}$:	260V
Line inductance:	0.5mH
DC bus Capacitance:	1200 μF ($2 \times 2400\mu F$).
DC bus Voltage:	380V in motoring 420V in braking
Load:	4Kw in motoring 3Kw in braking

5. Simulation Results

Comparison of two methods A and B shows that harmonics of current and voltage in method B is less than method A (Fig 9, 10)

In the method C, as shown in the Fig 11, the amplitude of harmonics, with respect to methods A and B is decreased, but this reform encounters by two additional IGBTs and one transformer. For better comparison of the three methods, harmonic calculation and bus voltage ripple factor in the 3 methods are listed in the table 1:

Table 1: Current harmonics and bus voltage ripple factor in three methods

Method	A	B	C
3th current harmonic	%23	%20	%2
5th current harmonic	%5	%4	%8
7th current harmonic	%1	%1	%9
Power Factor	0.78	0.85	0.92
Ripple Factor	%7	%6	%6

Loss in the method A is mostly on the inductor because of low switching frequency and thus small switching loss. But in method B, we can select small inductor so switching loss is dominant.

6. Conclusion

In this paper, methods of energy recovery for electric motors in braking mode are presented and for motors with low and medium regenerative power, a low cost and simple structure is proposed. Then two methods of operation for the proposed structure is presented. Simulation of the proposed methods and comparison with conventional methods are presented in Fig 9-11. Method A with most simplicity and method C with less harmonic generation are noticeable. According to cost and maximum acceptable harmonic we can choose any of the above structures.

7. References

- [1] R.Belmans, F.Busschots, and R.Timmer, "Practical design considerations for braking problems in overhead crane drives," *Conf. Rec. IEEE-IAS Annual Meeting*, Oct. 1993, vol.1, pp. 473-479.
- [2] N.Mohan, T.Undeland, and W.Robbins, *Power Electronics: Converters, Applications and Design*, 2nd Edition, 1995, John Wiley and Sons, New York.
- [3] VJ.Gosbell and P.P.Cugaly, "A low cost reversible rectifier," Proceedings of the IEEE International Symposium on Industrial Electronics, 1996, vol. 1, pp. 508-513.
- [4] Safronics Inc. Application Note, *SCR-Regenerative AC Drive*.
- [5] N.R.Raju, "An SCR-based Regenerative Converter for VSI Drives" *Conf. Rec. IEEE 2003*, pp. 7803-7754
- [6] J.M.Liptak, F.C.Joyner, and J.C.Guyeska, "Regenerative controller for a voltage-source inverter drive," *Conf. Rec. IEEE-IAS Annual Meeting*, Oct. 1985, pp. 1672-1677.
- [7] R.M.Davis and C.G.Alexander, "A bi-directional ac-dc power converter for fixed polarity d.c. loads," Proceedings of 3rd International Conference on Power Electronics and Variable Speed Drives, *IEE*, July 1988, vol. 1, pp. 142-145.
- [8] C.Schauder, "A regenerative two-quadrant converter for dc-link voltage source inverters," *Conf. Rec. IEEE-IAS Annual Meeting*, Oct. 1988, vol.1, pp. 954-960.
- [9] A.V. Radun, and Y. Q. Xiang, "Switched reluctance starter/generator system modeling results," *Trans. SAE, J. Aerosp.*, vol. 104, sec. 1, pp. 257-266, 1995.
- [10] M.Rashid, *Power electronics: circuit, device and applications*, 2nd ed. 1996, John Wiley and Sons, New York.

8. Simulation Figures

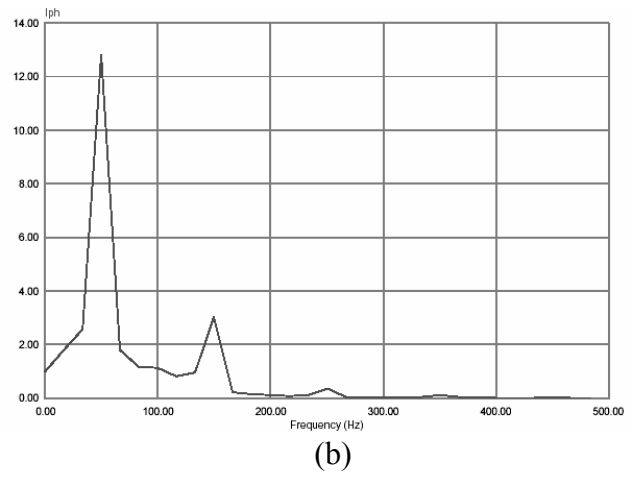
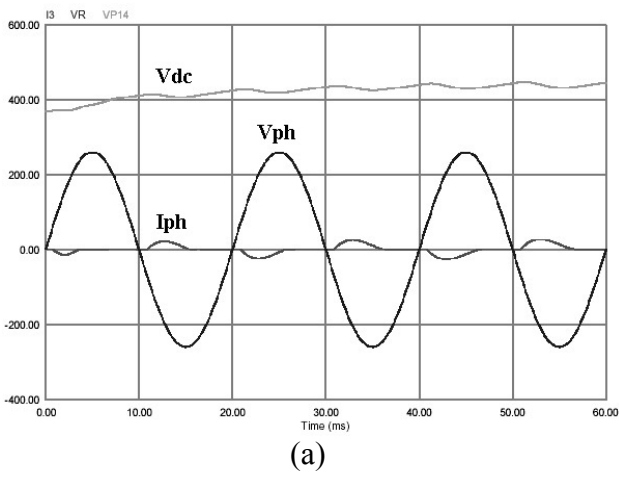

Fig 9: (a) diagram of phase voltage and Current in method A (b) spectrum of current in method A

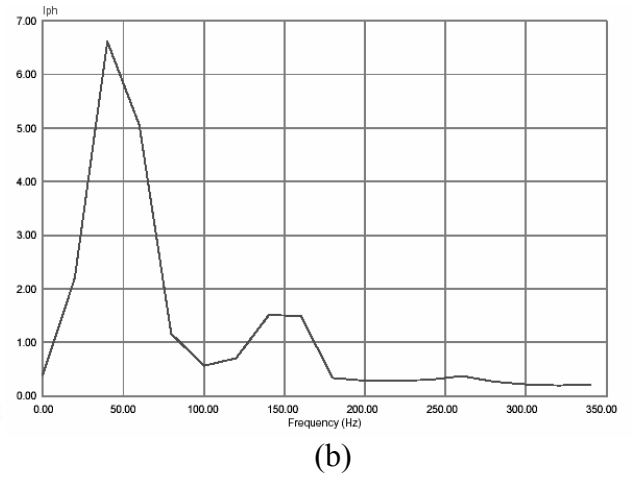
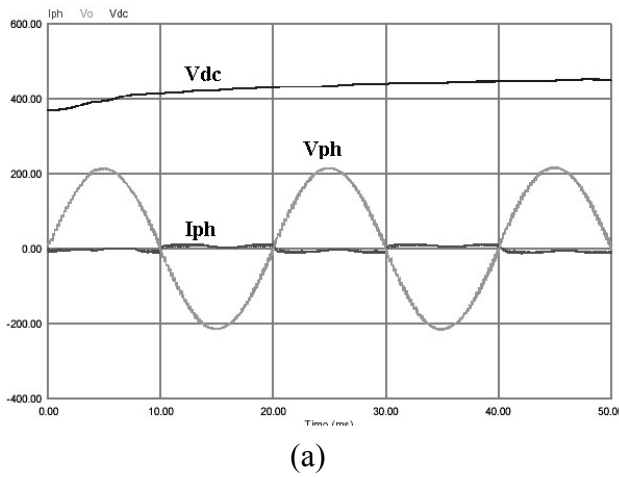

Fig 9: (a) diagram of phase voltage and Current in method B (b) spectrum of current in method B

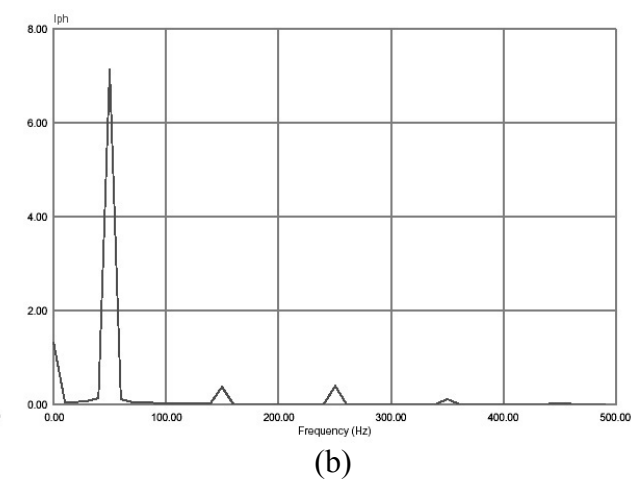
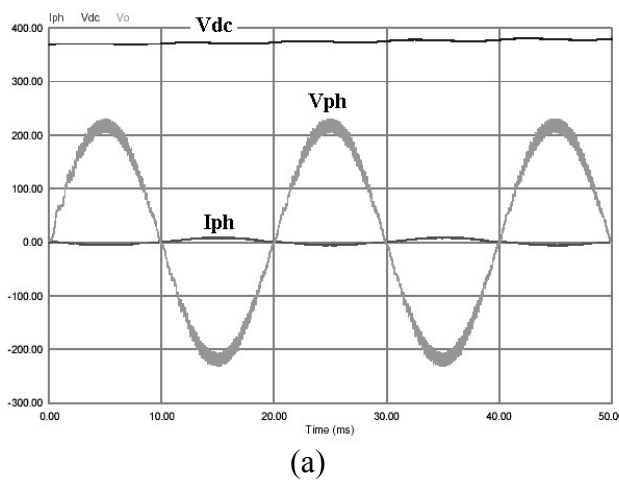

Fig 9: (a) diagram of phase voltage and Current in method C (b) spectrum of current in method C

FURTHER READING

Click any one of the following links to be taken to a website which contains the following documents.

There appears to be a lot of recent patent activity in the area of building "bridgeless PFC convertors". The following are some of the patents.

[11_584_983_Method_and_apparatus_for_high_efficiency_rectifier](#)
[11_204_307_AC_to_DC_power_supply_with_PF](#)
[11_302_544_Simple_partial_switching_power_factor_correction](#)
[11_474_712_BRIDGELESS_BI_DIRECTIONAL_FORWARD_TYPE_CONVERTER](#)
[11_480_004_High_efficiency_power_converter_system](#)
[11_706_645_AC_to_DC_voltage_converter_as_power_supply](#)
[12_401_983_BRIDGELESS_PFC_CIRCUIT_FOR_CRM](#)
[12_798_682_Bridgeless_PFC_converter](#)

[3295043_MASSEY_D_C_TO_D_C_REGULATED_CONVERTER](#)
[4183079_DC_AC_inverter](#)
[4523266_AC_to_DC_conversion_system](#)
[4943902_AC_to_DC_power_converter_and_method](#)
[5570276_Switching_converter_with_open_loop_input_regulation](#)
[5815380_Switching_converter_with_open_loop_Primary_regulation](#)
[5815384_Transformer_uses_bi_directional_synch_Rectifiers](#)
[6115267_AC_DC_converter_with_no_input_rectifiers](#)
[6157182_DC_DC_converter_with_multiple_operating_modes](#)
[6608522_DC_to_DC_converter_providing_stable_operation](#)
[7250742_Digital_control_of_bridgeless_power_factor_correction](#)
[7265591_CMOS_driver_with_minimum_shoot_through](#)

And here is some more information for those who may be interested.

[A BIDIRECTIONAL PWM THREE-PHASE STEP-DOWN RECTIFIER](#)
[A bidirectional, sinusoidal, high-frequency inverter](#)
[A DUAL INPUT BIDIRECTIONAL POWER CONVERTER](#)
[A new structure for bidirectional Power flow](#)
[BI-DIRECTIONAL INVERTER-CHARGER](#)
[Bi-directional single-phase half-bridge rectifier for power quality](#)
[BiDirectional Converter](#)
[Bidirectional UP Inverter](#)
[Synthesis of Input-Rectifierless AC/DC](#)

11.28.10 10.11AM
dsauersanjose@aol.com
Don Sauer
<http://www.idea2ic.com/>