

# UNDERSTANDING AND USING 'OTA' OP-AMP ICs

by Ray Marston

Part 2

Ray Marston looks at the operating principles and practical applications of the LM13700 dual Operational Transconductance Amplifier (OTA) IC in this concluding episode of a two-part mini-series.

Last month's opening episode of this two-part mini-series described basic 'OTA' operating principles, and took a close look at the popular and widely available CA3080 OTA IC. The CA3080 is actually a simple, first-generation OTA that generates fairly high levels of signal distortion and has a high-impedance unbuffered output. This month's concluding episode describes an improved second-generation OTA IC — the LM13700 — which does not suffer from these snags.

The LM13700 is actually a dual OTA, as indicated by the pin connection diagram in Figure 1. Each of its OTAs is an improved version of the CA3080, and incorporates input linearizing diodes that greatly reduce signal distortion, and have an optional buffer stage that can be used to give a low impedance output. The LM13700 is, in fact, a very versatile device, and can easily be made to act as a voltage-controlled amplifier (VCA), voltage-controlled resistor (VCR), voltage-controlled filter (VCF), or voltage-controlled oscillator (VCO), etc.

## LINEARIZING DIODES

The CA3080 OTA consists of (as described last month) a differential amplifier plus a number of current mirrors that give an output equal to the difference between the amplifier's two collector currents, as shown in the simplified circuit in Figure 2. A weakness of this circuit is that its input signals must be limited to 25mV peak-to-peak if excessive signal distortion is not to occur. This distortion is caused by the inherently non-linear  $V_{be}$ -to- $I_c$  transfer characteristics of Q1 and Q2.

Figure 3 shows the typical transfer characteristics graph of a small-signal silicon transistor. Thus, if this tran-

sistor is biased at a quiescent collector current of 0.8mA, an input signal of 10mV peak-to-peak produces an output current swing of +0.2mA to -0.16mA, and gives fairly small distortion. But an input swing of 30mV peak-to-peak produces an output swing of +0.9mA to -0.35mA, and gives massive distortion. In practice, the CA3080 gives typical distortion figures of about 0.2% with a 20mV peak-to-peak input, and a massive 8% with a 100mV peak-to-peak input.

Figure 4 shows the basic 'usage' circuit of one of the improved second-generation OTAs of the LM13700, which is almost identical to that of the CA3080, except for the addition of linearizing diodes D1 and D2, which are integrated with Q1 and Q2, and thus have characteristics matched to those of the Q1 and Q2 base-emitter junctions. In use, equal, low-value resistors — R1 and R2 — are wired between the inputs of the differential amplifier and the common supply line, and bias current  $I_D$  is fed to them from the positive supply rail via R3 and D1-D2 and, since D1-D2 and R1-R2 are matched, divides equally between them to give R1 and R2 currents of  $I_D/2$ .

The circuit's input voltage is applied via R4 (which is large relative to R1) and generates input signal current  $I_s$ , which feeds into R1 and thus generates a signal voltage across it that reduces the D1 current to  $(I_D/2) - I_s$ . The  $I_D$  current is, however, constant, so the D2 current rises to  $(I_D/2) + I_s$ . Consequently, the linearizing diodes of the Figure 4 circuit apply heavy, negative feedback to the differential amplifier and give a large reduction in signal distortion. If  $I_s$  is small relative to  $I_D$ , the output signal current of the circuit is equal to  $2 \times I_s \times (I_{bias}/I_D)$ . Thus, the circuit's gain can be controlled via either  $I_{bias}$  or  $I_D$ .

The OTAs of the LM13700 can be used as simple OTAs of the CA3080 type by ignoring the presence of the two linearizing diodes, or can be used as low-distortion amplifiers by using the diodes as shown in Figure 4. The graph in Figure 5 shows typical distortion levels of the LM13700 at various peak-to-peak values of input signal

voltage, with and without the use of linearizing diodes. Thus, at 30mV input, distortion is below 0.03% with the diodes, but 0.7% without them, and at 100mV, input is roughly 0.8% with the diodes, but 8% without them.

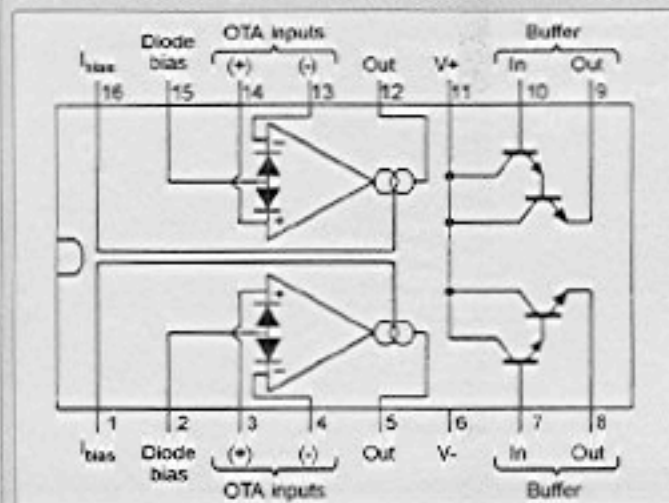

Figure 1. Pin connections of the LM13700 dual OTA IC.

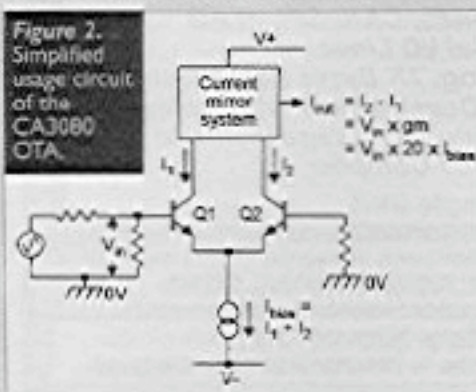

Figure 2. Simplified usage circuit of the CA3080 OTA.

$$I_{out} = I_2 - I_1$$

$$= V_{in} \times g_m$$

$$= V_{in} \times 20 \times I_{bias}$$

## INTERNAL BUFFERS

Figure 6 shows the internal circuit of each half of the LM13700 IC package. If this circuit is compared with that of the CA3080 shown last month, it will be seen to be broadly similar except for the addition of linearizing diodes D1-D2 to the inputs of the OTA's Q1-Q2 differential amplifier, and the addition of output transistors Q11-Q12, which are configured as a Darlington emitter follower buffer stage and can (by wiring its input to the OTA output and connecting Q12 emitter to the negative rail via a suitable load resistor) be used to make the high-impedance output of the OTA available at a low-impedance level. Note in this latter case that the output of the buffer stage is two base-emitter volt drops (about 1.2V) below the output voltage level of the OTA, so this buffer is not suited for use in high-precision DC amplifier applications.

The two OTAs of the LM13700 share common supply rails, but are otherwise fully independent. All elements are integrated on a single chip, and the OTAs have closely-matched characteristics ( $g_m$  values are typically matched within 0.3dB), making the IC ideal for use in stereo VCA and VCF applications, etc. The standard commercial version of the LM13700 can be powered from split supply rails of up to  $\pm 18V$ , or single-ended supplies of up to 36V. In use,  $I_D$  and  $I_{bias}$  should be limited to 2mA maximum, and the output current of each buffer stage should be limited to 20mA maximum.

The two OTAs of the LM13700 share common supply rails, but are otherwise fully independent. All elements are integrated on a single chip, and the OTAs have closely-matched characteristics ( $g_m$  values are typically matched within 0.3dB), making the IC ideal for use in stereo VCA and VCF applications, etc. The standard commercial version of the LM13700 can be powered from split supply rails of up to  $\pm 18V$ , or single-ended supplies of up to 36V. In use,  $I_D$  and  $I_{bias}$  should be limited to 2mA maximum, and the output current of each buffer stage should be limited to 20mA maximum.

## VCA CIRCUITS

Figure 7 shows a practical voltage-controlled amplifier (VCA) made from half of an LM13700 IC. Here, the input signal is fed to the non-inverting terminal of the OTA via current-limiting resistor R4, and the high-impedance output of the OTA is loaded by R5, which determines the peak (overload) amplitude of the output signal in the way described last month. The output signal is made available to the outside world at a low-impedance level via the buffer stage, which is loaded via R6.

The Figure 7 circuit is powered from dual 9V supplies. The  $I_D$  current is fixed at about 0.8mA via R1, but  $I_{bias}$  is variable via R7 and an external gain control voltage. When the gain-control voltage is at the negative rail value of -9V,  $I_{bias}$  is zero and the circuit gives an overall 'gain' of -80dB. When the gain-control is at the positive rail value of +9V,  $I_{bias}$  is about 0.8mA, and the circuit gives a voltage gain of

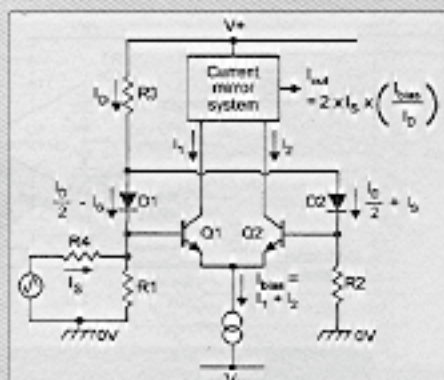

Figure 4. Simplified usage circuit of an LM13700 OTA.

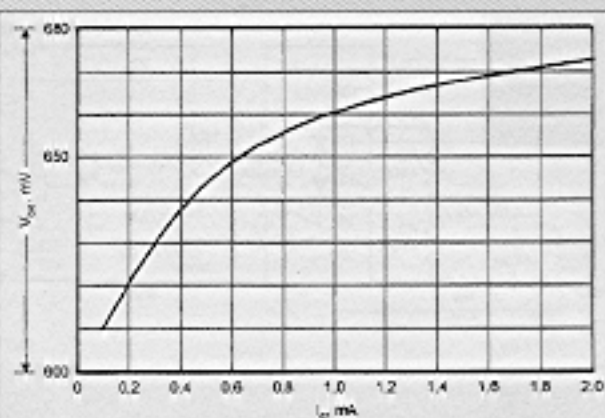

Figure 3. Typical transfer characteristics of a small-signal silicon transistor.

roughly  $\times 1.5$ . The voltage gain is fully variable within these two limits via the gain-control input. The two halves of the LM13700 have closely-matched characteristics, making the IC ideal for use in stereo amplifier applications. Figure 8 shows how two amplifiers of the Figure 7 type can be used together to make a voltage-controlled stereo amplifier. Note, in this case, that the  $I_{bias}$  gain-control pins of the two OTAs are shorted together and fed from a single gain-control voltage and current-limiting resistor. The close matching of the OTAs ensures that the gain-control currents divide equally between the two amplifiers.

Note that the Figure 7 and 8 circuits act as non-inverting amplifiers, since their input signals are fed to the non-inverting pins of the OTAs. They can be made to act as inverting amplifiers by simply feeding the input to the inverting pins of the OTAs.

The VCA circuit in Figure 7 can be used as an amplitude modulator or two-quadrant multiplier by feeding the carrier signal to the input terminal, and the modulation signal to the gain-control input terminal. If desired, the gain-control pin can be DC biased so that a carrier output is available with no AC input signal applied. Figure 9 shows a practical example of an inverting amplifier of this type. The AC modulation signal modulates the amplitude of the carrier output signal.

Figure 10 shows how half of an LM13700 can be used as a ring modulator or four-quadrant multiplier, in which zero carrier output is available when the modulation voltage is at zero (common supply rail) volts, but increases when the

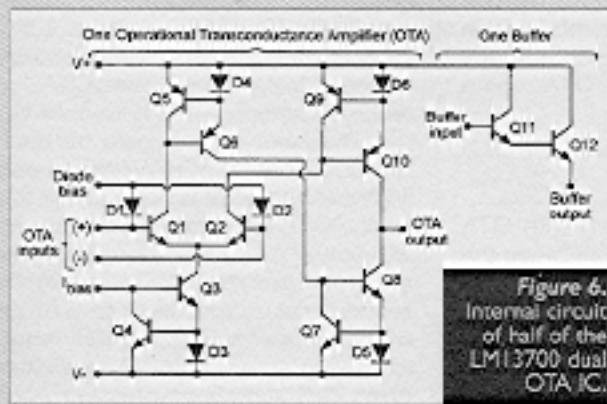

Figure 6. Internal circuit of half of the LM13700 dual OTA IC.

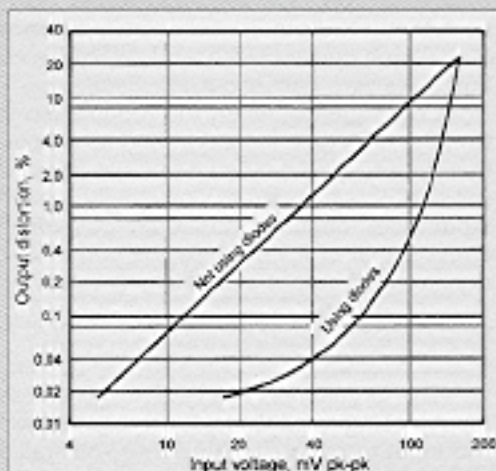

Figure 5. Typical distortion levels of the LM13700 OTA, with and without the use of the linearizing diodes.

Figure 7. Voltage-controlled amplifier (VCA).

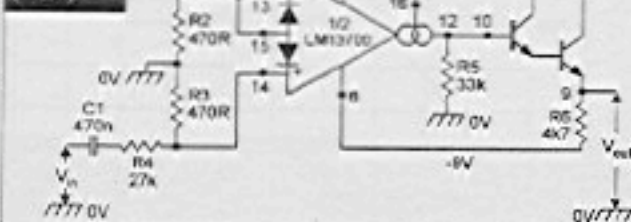
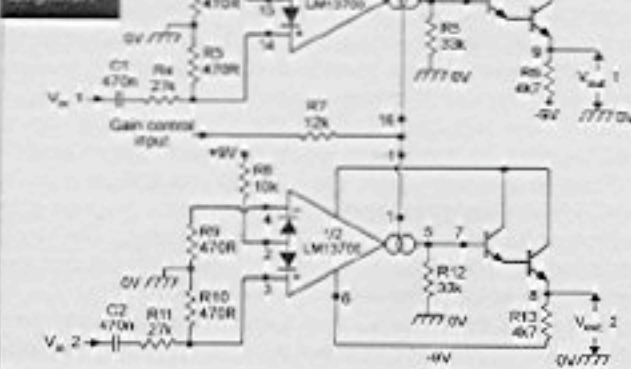

Figure 8. Voltage-controlled stereo amplifier.



modulation voltage moves positive or negative relative to zero. When the modulation voltage is positive, the carrier output signal is inverted relative to the carrier input, and when the modulation voltage is negative, the carrier is non-inverted.

The Figure 10 circuit is shown with values suitable for operation from dual 15V supplies, but is essentially similar to the Figure 9 circuit, except that R5 is connected between the input signal and the output of the OTA, and  $I_{bias}$  is "pre-settable" via RV1. The basic circuit action is such that the OTA feeds an inverted (relative to the input) signal current into the bottom of R5, and at the same time, the input signal feeds directly into the top of R5. RV1 is pre-set so that when the modulation input is tied to the zero volts common line, the overall gain of the OTA is such that its output current exactly balances (cancels) the direct-input current of R5, and under this condition, the circuit gives zero carrier output.

Consequently, when the modulation input goes positive, the OTA gain increases and its output signal exceeds that caused by the direct input into R5, so an inverted output carrier is generated. Conversely, when the modulation input goes negative, the OTA gain decreases and the direct signal of R5 exceeds the output of the OTA, and a non-inverted output signal is generated.

## OFFSET BIASING

The circuits in Figures 7 to 10 are shown with OTA input biasing applied via 470R resistors wired between the two input terminals and the zero volts rail. In practice, this simple arrangement may cause the DC output level to shift slightly when the  $I_{bias}$  gain-control is varied from minimum value. If desired, this shifting can be eliminated by fitting the circuits with a pre-settable offset adjust control

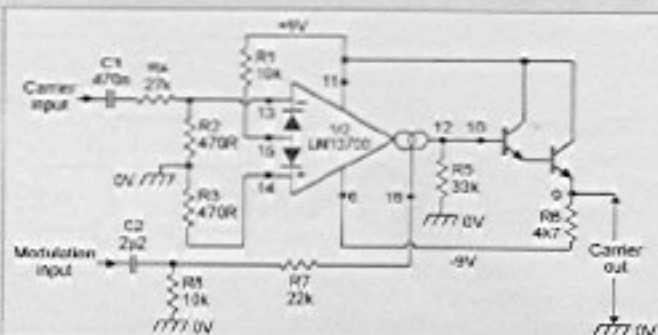

Figure 9. Amplitude modulator or two-quadrant multiplier.

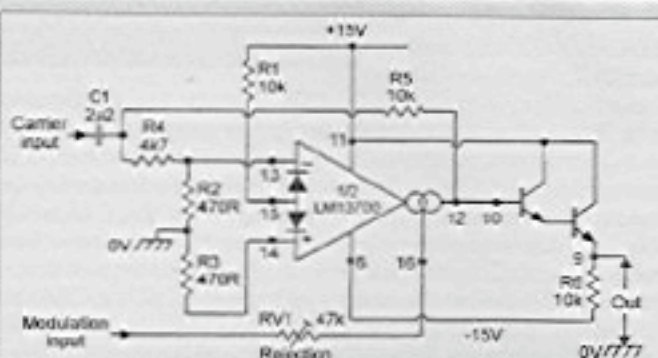

Figure 10. Ring modulator or four-quadrant multiplier.

as shown in Figure 11, enabling the biasing resistance values to be varied slightly. To adjust the offset biasing, reduce  $I_{bias}$  to zero, note the DC level of the OTA output, then increase  $I_{bias}$  to maximum and adjust RV1 to give the same DC output level.

## AN AUTOMATIC GAIN CONTROL AMPLIFIER

In the Figures 7 to 10 circuits, the amplifier gain is varied by altering the  $I_{bias}$  value. A feature of the LM13700, however, is that its gain can be varied by altering either the  $I_{bias}$  or the  $I_D$  current, and Figure 12 shows how the  $I_D$  variation can be used to make an automatic gain control (AGC) amplifier in which a 100:1 change in input signal amplitude causes only a 5:1 change in output amplitude.

In this circuit,  $I_{bias}$  is fixed by R4, and the output signal is taken directly from the OTA via R5. The output buffer is used as a signal rectifier — fed from the output of the OTA — and the rectified output is smoothed via R6-C2, and used to apply the  $I_D$  current to the OTA's linearizing diodes. Note, however, that no significant  $I_D$  current is generated until the OTA output reaches a high enough amplitude ( $3 \times V_{be}$ , or about 1.8V peak) to turn on the Darlington buffer and the linearizing diodes, and that an increase in  $I_D$  reduces the OTA gain and — by negative feedback action — tends to hold  $V_{out}$  at that level.

The basic zero  $I_D$  gain of this amplifier is  $\times 40$ . Thus, with an input of 30mV peak-to-peak, the OTA output of 1.2V peak-to-peak is not enough to generate an  $I_D$  current, so the OTA operates at full gain. At 300mV input, however, the OTA output is enough to generate significant  $I_D$  current, and the circuit's negative feedback automatically reduces the output level to 3V6 peak-to-peak, giving an overall gain of  $\times 11.7$ . With an input of 3V, the gain falls to  $\times 2$ , giving an output of 6V peak-to-peak. The circuit, thus, gives 20:1 signal compression over this range.

## VOLTAGE-CONTROLLED RESISTORS

An unusual application of the LM13700 is as a voltage-controlled resistor (VCR), using the basic circuit in Figure 13. The basic theory here is quite simple — if an AC signal is applied to the  $R_x$  terminals, it will feed to the OTA's inverting terminal via C1 and the buffer stage and the  $R/RA$  attenuator, and the OTA will then generate an output current proportional to the  $V_{in}$  and  $I_{bias}$  values. Thus, since  $R_x = E/I$ , the circuit's  $R_x$  terminal acts like an AC resistor with a value determined by  $I_{bias}$ .

The effective resistance value of the  $R_x$  terminal actually equals  $(R + RA)/(gm \times RA)$ , where  $gm$  is roughly  $20 \times I_{bias}$ . This formula approximates to  $R_x = R/(I_{bias} \times 20RA)$ , so, using the component values shown in the diagram,  $R_x$  equals roughly  $10M$  at an  $I_{bias}$  value of  $1\mu A$ , and  $10k$  at an  $I_{bias}$  of  $1mA$ . Figure 14 shows a similar version of the VCR, where the linearizing diodes are used to effectively improve the noise performance of the resistor, and Figure 15 shows how a pair of these circuits can be used to make a floating VCR in which the input voltage is direct-coupled and may be at any value within the output voltage range of the LM13700.

## VOLTAGE-CONTROLLED FILTERS

An OTA acts basically as a voltage-controlled AC current source, in which an AC voltage is applied to the amplifier's input, and the magnitude of the output current depends on the value of  $I_{bias}$ . This fact can be used to implement a voltage-controlled low-pass filter by using half of an LM13700 in the configuration shown in Figure 16, in which the values of  $R$ ,  $C$ , and  $I_{bias}$  control the cut-off frequency,  $f_{co}$ , of the filter. The operating theory of this circuit is as follows.

Assume, initially, that capacitor  $C$  is removed from the circuit. The input signal is applied to the OTA's non-inverting terminal via potential divider  $R1-R2$ , and the OTA's output is followed by the buffer stage and fed back to the inverting input via an identical divider made up of  $R$  and  $RA$ . The basic OTA thus acts as a non-inverting amplifier with a gain of  $R/RA$  but, since the input signal is fed to the OTA via a potential divider with a value equal to  $R/RA$ , the circuit acts overall as a unity-gain voltage follower.

Assume now that capacitor  $C$  is fit into place. At low frequencies,  $C$  has a very high impedance and the OTA output current is able to fully charge it, causing the circuit to act as a voltage follower in the way already described.

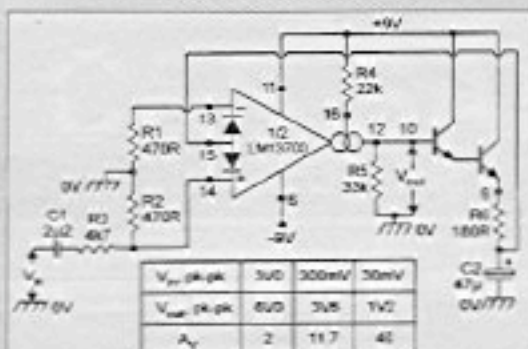

Figure 12. Circuit and performance table of an AGC amplifier.

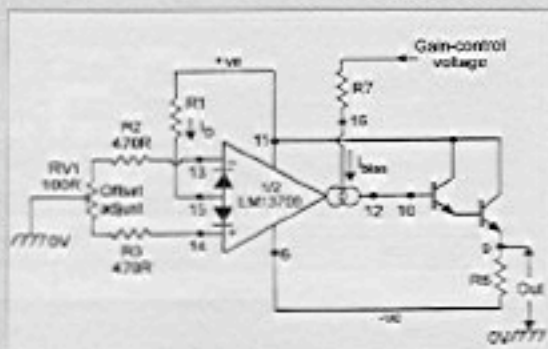

Figure 11. Method of applying offset biasing to the LM13700.

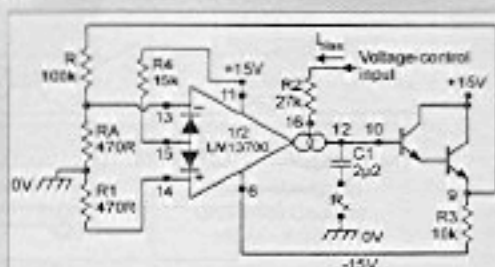

Figure 14. Voltage-controlled resistor with linearizing diodes.

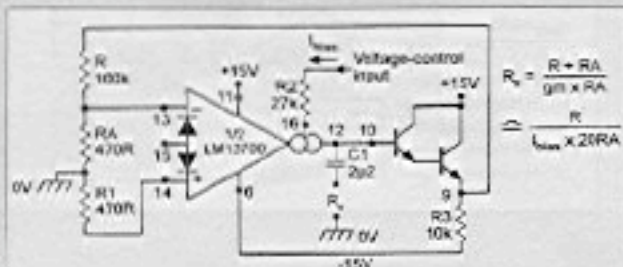

Figure 13. Voltage-controlled resistor, variable from 10k to 10M via  $I_{bias}$ .

As the frequency increases, however, the impedance ( $X$ ) of  $C$  decreases and the OTA output current is no longer able to fully charge  $C$ , and the output signal starts to attenuate at a rate of 6dB per octave. The cut-off point of the circuit — at which the output falls by 3dB — occurs when  $XC/20I_{bias}$  equals  $R/RA$ , as implied by the formula in the diagram. With the component values shown, cut-off occurs at about 45Hz at an  $I_{bias}$  value of  $1\mu A$ , and at 45kHz at an  $I_{bias}$  value of  $1mA$ . A similar principle to the above can be used to make a voltage-controlled high-pass filter, as shown in Figure 17. This particular circuit has, with the values shown, cut-off frequencies of 6Hz and 6kHz at  $I_{bias}$  currents of  $1\mu A$  and  $1mA$ , respectively.

Numbers of filter stages can easily be cascaded to make multi-pole voltage-controlled filters. The excellent tracking of the two sections of the LM13700, make it possible to voltage-control these filters over several decades of frequency. Figure 18 shows the practical circuit of a two-pole (12dB per octave) Butterworth low-pass filter having cut-off frequencies of 60Hz and 60kHz at  $I_{bias}$  currents of  $1\mu A$  and  $1mA$ , respectively.

## VOLTAGE CONTROLLED OSCILLATORS

To conclude this look at applications of the LM13700,

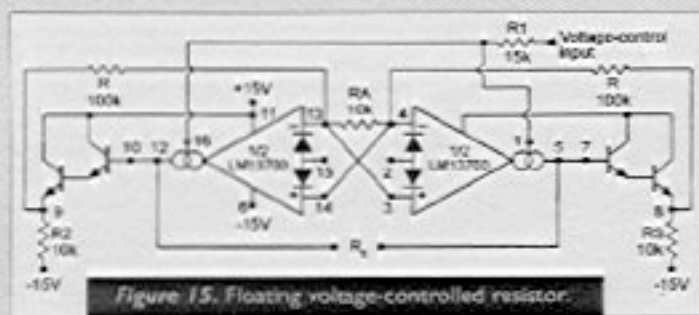

Figure 15. Floating, voltage-controlled resistor.

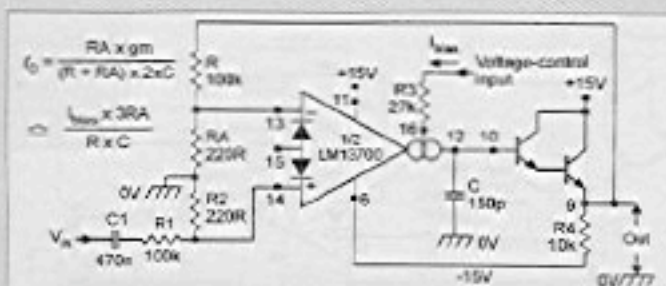

Figure 16. Voltage-controlled, low-pass filter covering 45Hz to 45kHz.

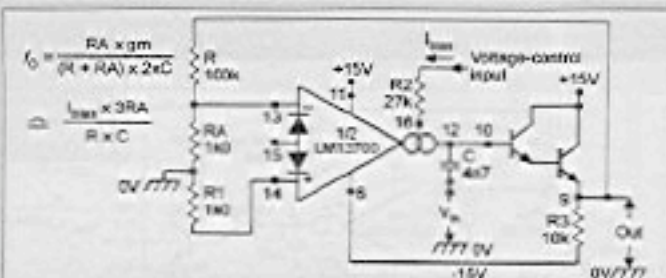

Figure 17. Voltage-controlled, high-pass filter covering 6Hz to 6kHz.

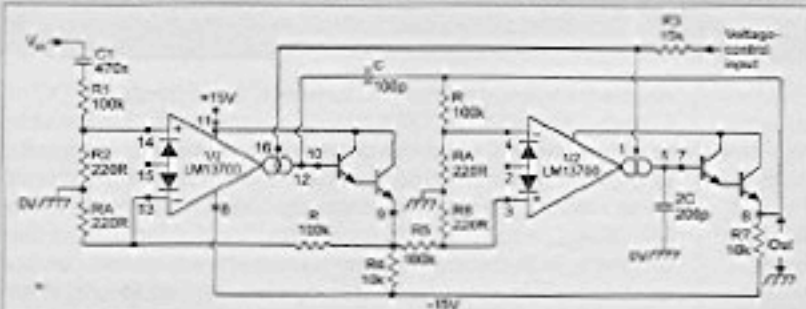

Figure 18. Voltage-controlled two-pole Butterworth low-pass filter covering 60Hz to 60kHz.

Figures 19 and 20 show two ways of using the IC as a voltage-controlled oscillator (VCO). The Figure 19 circuit uses

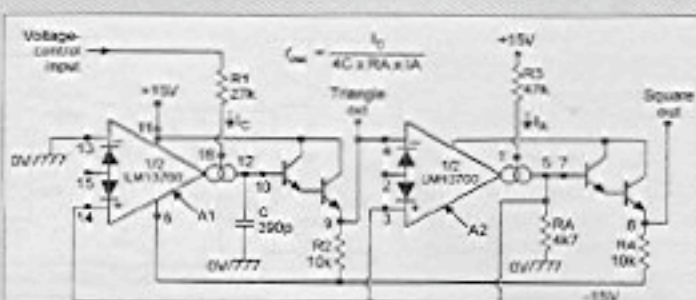

Figure 19. Triangle/squarewave VCO covering 200Hz to 200kHz.

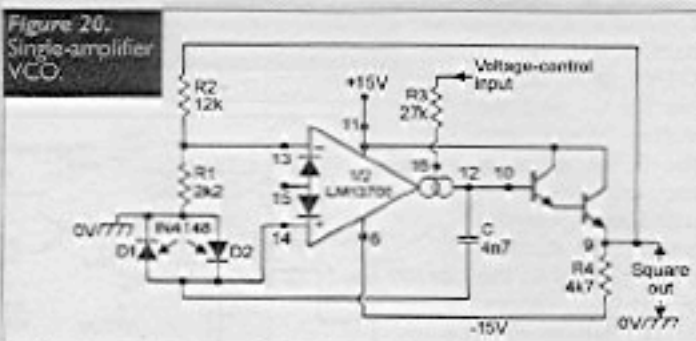

Figure 20. Single-amplifier VCO.

both halves of the LM13700, and simultaneously generates both triangle and squarewaves. The Figure 20 design uses only half of the IC, and generates squarewaves only.

To understand the operating theory of the Figure 19 circuit, assume initially that capacitor C is negatively charged and that the squarewave output signal has just switched high. Under this condition, a positive voltage is developed across RA and is fed to the non-inverting terminals of the two amplifiers, which are both wired in the voltage comparator modes.

This voltage makes amplifier A1 generate a positive output current equal to the bias current,  $I_C$ , and this flows into capacitor C, which generates a positive-going linear ramp voltage that is fed to the inverting terminal of A2 via the Darlington buffer stage until, eventually, this voltage equals that on the non-inverting terminal, at which point the output of A2 starts to swing negative. This initiates a regenerative switching action in which the squarewave output terminal switches abruptly negative.

Under this condition, a negative voltage is generated across resistor RA, causing amplifier A1 to generate a negative output current equal to  $I_C$ . This current causes capacitor C to discharge linearly until, eventually, its voltage falls to a value equal to that of RA, at which point the squarewave output switches high again. This process repeats *ad infinitum*, causing a triangle waveform to be generated on R2 and a squarewave output to be generated on R4.

The waveform frequency is variable via the voltage-control input, which controls the value of  $I_C$ . With the component values shown, the circuit generates a frequency of about 200Hz at an  $I_C$  current of 1 $\mu$ A and 200kHz at a current of 1mA.

Finally, Figure 20 shows a single-amplifier VCO circuit which generates a squarewave output only. The circuit operates in a similar manner to that described above, except that 'C' charges via D1 and discharges via D2, which generates a 'polarity' signal on the non-inverting terminal of the amplifier. NV

Weeder Technologies

RS-232 Stackable

1719-B Brighton Cove, Ft. Walton Beach, FL 32647      850-863-6723

Digital I/O Module - 14 I/O channels individually configured for input or output. Turn on/off relays. Sense switch closures, button presses and 4x4 matrix decoding using auto-debounce and typematrix repeat with adjustable delay. One-shot pulse output. \$69

Analog Input Module - 8 single-ended or 4 differential inputs. Self-calibrated, 12-bit ADC, needs voltages from 0 to 4096 mV. High & Low alarm trip points for each input. \$69

Analog Output Module - 4 outputs that span -10 to +10 volts using 12-bit DAC. Built-in ramp generator, software calibrated, user selectable PCFI defaults for each channel. \$69

Stepper Motor Driver - Directly drives a unipolar stepper motor rated up to 30VDC @ 3A. Self-generated S-curve acceleration profiles provide smooth start and stop motion. Software programmable ramp-rate, velocity and idle current. Single phase, dual phase, & half-step drive modes. 24-bit absolute motor position counter. \$79

Pulse Counter/Timer - Read frequency from 2.50000 Hz to 1,000,000 Hz using floating decimal point and 5-digit resolution throughout range. Measure period, RPM, duty cycle, pulse length, the velocity of a projectile using a pair of trip wires. 24-bit pulse count accumulator for event counting. \$79

Solid State Relay Module - 5 opto isolated relays can be wired directly to existing low-current buttons and switches to provide software control of their operation. Built-in event sequencer. \$69

Plug end-to-end

Stack 32 modules on the same RS-232 cable.